

EN ISO 9001:2015
TUV NORD



BUFFER TANK WARRANTY

- > SAFETY INSTALLATION CONDITIONS
 - > SAFETY RECOMMENDATIONS FOR THE INSTALLATION AND MAINTENANCE OF THE BUFFER TANK
-



Read carefully the safety installation manual, maintenance and warranty terms before installing the device, so as to avoid possible damage and to protect yourself from any risks.

CONTENTS

WATER HEATER TANK WARRANTY

| | |
|-------------------------------------------------|---|
| THE COMPANY OFFERS THE FOLLOWING WARRANTY | 3 |
| WARRANTY TERMS | 3 |
| THE WARRANTY DOES NOT COVER..... | 4 |

SAFE INSTALLATION CONDITIONS

| | |
|----------------------------------------|---|
| GENERAL INSTRUCTIONS..... | 4 |
| INSTALLATION & SPACE REQUIREMENTS..... | 5 |
| INSTALLATION PARTICULARITIES..... | 5 |
| WORKING CONDITIONS..... | 5 |
| PERSONNEL REQUIREMENTS..... | 5 |
| DEVICE TRANSPORTATION..... | 5 |
| RECOMMENDED SYSTEM INSPECTIONS..... | 5 |
| SYSTEM CHECK UPS..... | 5 |

DIMENSION & EXPLANATORY DRAW

6

TRANSFERRING THE BUFFER TANK

7

POSITIONING THE BUFFER TANK.....

7

INITIAL START OF BUFFER TANK

| | |
|--------------------------|---|
| LEAK TEST | 7 |
| SAFETY RELIEF VALVE..... | 8 |
| OPERATING TIPS..... | 8 |

MAINTENANCE.....

8

MAGNESIUM ANODE CHECK.....

8

MAINTENANCE BOOK.....

9

TEXT MARK EXPLANATIONS:



SAFETY TIPS



LEGAL NOTE



IMPORTANT INFORMATION

WATER HEATER TANK WARRANTY

THE COMPANY OFFERS THE FOLLOWING WARRANTY:

> For the heat tank five (5) years warranty.

FURTHERMORE, THE WARRANTY IS VALID ONLY WHEN THE FOLLOWING TERMS ARE SATISFIED:

1. The heat tank must be installed and maintained by specified and certified personnel.
2. The magnesium bar of the heat tank, must necessarily be checked every year and it must be replaced instantly if it has been outworn to a percentage above 50% or it has been covered by the accumulation of salts.
3. The standard of the water quality used by the system should not be lower than the potable (page 4 table)
4. The tank should be grounded.
5. The water supply pressure should not exceed 6 bars, otherwise a pressure reducer should be installed.
6. System temperature and pressure should not exceed the specifications as indicated in the device's technical manual.
7. The tank should always have safety valves that will protect the system from the maximum temperature and maximum operating pressure. For the proper operation of the heat tank, it is necessary to check the safety valves and in case of malfunction must be replaced .
8. The area where the system is to be installed must have a functional water drainage on the floor.
9. The user must take all appropriate measures to exclude the overheating phenomenon.
10. The hydraulic connections to the tank must be such as to exclude the phenomenon of electrolysis.
11. The tank should not be damaged by a drop or a hit during transport or installation.
12. Maintenance of the heat tank must be in accordance with the maintenance schedule which the installer has design.
13. The installer and maintainer should record the tasks and the reason why they were called in the maintenance book. This record file is a key element of the warranty and should be made available on request.
14. All repairs or maintenance must be carried out using quality spare parts which are specific indicated in the device's maintenance book. Under no circumstances should you exercise any welding on the tank's metal structure. You risk to deteriorate or destroy the tank.
15. The installation must meet the conditions described in the installation manual which is an integral part of the warranty.
16. The tank does not feature a heating element. Upon request by the user a heating element may be placed in any of the free sockets indicated only by a certified installer and a certified electrician. Only special heating element shall be placed in the tank. The certified installer is responsible to indicate the appropriate position and type of the heating element – always guided by the instructions provided by the heating element manufacturer. The constant and unreasonable use of the heating element may cause damage to the tank and will set it beyond warranty.

CAUTION!



Safety tips

The active part of the heating element shall not be inside the socket (tank's coupling or neck). Instead it shall be as closer as possible to the center of the tank, so as the heated water can be naturally alternated over the heating element's surface.

The tank shall always be placed on a totally flat surface (without any inclination) so that no air is captured in the couplings or any other part, especially if this part is close to the heating element.

The heating element shall always be totally covered by water.

ATTENTION!



Very poor water quality at the water outlet can result in salt formation and salts may block the safety valve. In this case, the tank remains unprotected against very high temperatures above 95°C and high pressure (greater than 6 bars).



THE WARRANTY DOES NOT COVER:

- > The magnesium rod in the tank.
- > Damage to the heating element.
- > Damage to safety valves (if are included in the tank's packaging) of the tank, by excessive concentration of salts or external bodies.
- > Tank damage due to excessive pressure of the water supply network.
- > Damage of the tank caused by overheating.
- > Damage caused by unauthorised third party intervention.
- > Damage caused by improper maintenance.
- > Damage caused by extreme operating conditions and extrinsic factors (*vandalism, fire, etc.*).
- > The sealing flange

NOTE:

In the event of a breakdown, the workshop's fees and transport costs are borne by the customer in any case. The manufacturer reserves the right to change the terms without notice.

WATER SPECIFICATIONS TABLE

| ELEMENT | PRICES |
|----------------|------------------|
| pH | 7–9 |
| Total hardness | 6–15° dH |
| Chlorides | < 100 mg/l |
| Free chlorine | < 0,5 mg/l |
| Sulphates | < 80 mg/l |
| Conductance | < 650 mS/cm 25°C |

SAFE INSTALLATION CONDITIONS

This is an integral part of the warranty to which it refers. It is not an installation guide. It refers to the appropriate conditions for a safe and right installation.

GENERAL INSTRUCTIONS

1. This manual is an essential and indispensable part of this device. It has to be carefully kept and always accompany the device.
2. Please read the instructions and warnings carefully. They contain crucial information concerning the safe installation, operation and maintenance of this new device.
3. The responsibility of installation lies with the buyer and has to be performed by an authorized specialist.
4. Using the device for reasons other than those specified in the manual is strictly prohibited. The manufacturer shall not be held liable for any damage caused by improper or unjustifiable use or by failure to comply with the instructions in the manual.
5. Installation, maintenance, and other special work on the device have to be performed by a specialist, always in compliance with existing instructions provided by the manufacturer.
6. Faulty installation may cause personal injury or damage your property. The manufacturer shall not be held liable for such damage.
7. Keep all packaging materials (*clips, plastic bags, polystyrene foam*) out of reach of children, as hazards may occur.

8. All repairs must be performed exclusively by an authorized specialist, using only the appropriate parts. Failing to comply with the instructions above may affect your safety and relieves the manufacturer of all responsibility.

CAUTION!



The installation must comply with local regulations, concerning hydraulic and electrical installations. Removing the packaging must be done on site, in order to protect the device from being damaged.

RISK TO HEALTH



Improper installation work can contaminate the potable water.

- Install the buffer tank hygienically and thoroughly and in accordance with current standards
- Rinse the buffer tank and piping thoroughly with potable water.

Install and equip the potable water pipes according to your country's applicable regulations and instructions.

INSTALLATION & SPACE REQUIREMENTS FOR THE INSTALLATION



Before installing the water heater tank, you have to choose the right location carefully and check the surface, to ensure it can bear the device's weight. The water heater tank must be installed on a flat surface with adequate bearing capacity.

INSTALLATION PARTICULARITIES

In case the chosen surface is not compatible with the standard equipment provided, another kind of equipment will have to be used. Responsibility for choosing the equipment lies solely on the installation expert and not on the manufacturer. It is up to the installation expert, whether they will suggest using another kind of equipment to the customer, to which the customer has to have agreed upon prior to the installation.

WORKING CONDITIONS

Keep the installation area clean and free of objects that may hinder the installation process. Do not allow other people, apart from the installation expert, to get near the tools, as well as the installation location. Use only parts that are compatible with the water heater you bought. The use of other parts or unsuitable tools may cause accidents or pose other hazards.

PERSONNEL REQUIREMENTS

The installation of water heaters has to be performed exclusively by authorized installation experts (*technicians*). Always wear protective glasses, suitable working attire, protective shoes and helmet. In hazardous locations, all protection measures must be taken and only special equipment must be used.

DEVICE TRANSPORTATION:

Transportation and handling of the tank

Abrupt movements must be avoided during the transportation of the tank, as they may result in fall and damage.

- You must be extremely careful while lifting the tank and always take precautions, in order to avoid possible accidents, injuries and other hazards.
- To avoid damaging the tank, do not remove the packaging, until it reaches the installation location.
- Do not place the tank on hard or uneven surfaces.

RECOMMENDED SYSTEM INSPECTIONS



ATTENTION!

BECAUSE SYSTEM MAINTENANCE AND CONTROL ARE DEPENDING FROM EVERY LOCAL CLIMATE DATA, WATER QUALITY AND THE OWNERS USAGE THE MAINTENANCE FREQUENCY IS PART OF THE AGREEMENT BETWEEN THE SYSTEM OWNER AND THE MAINTAINER INSTALLATION AND SYSTEM CONTROLS MUST ALWAYS BE PERFORMED BY AUTHORIZED SPECIALISTS. THE DATA OF MAINTENANCE SHOULD BE ALWAYS RECORDED IN THE MAINTENANCE BOOK FROM THE INSTALLER.

SYSTEM CHECK UPS

- Annually – preferably before the start of the high usage period to ensure that the heater operates properly and all the parts are in good working condition.
- Maintenance periods are determined upon delivery of the heater. During maintenance, you have to make sure that the following parts work properly:
 - Heat exchanger circuit
 - All joints and pipes for leaks
 - Magnesium anodes
 - Pipes insulation
 - Safety valves
 - Sealing flange

ATTENTION!



IN CASE THAT ALL THE NECESSARY MEASURES ARE NOT TAKEN AND THE SYSTEM IS OVERHEATED, EXCEEDING THE SAFETY TEMPERATURE OF 95°C, THEN THE SYSTEM IS OUT OF THE WARRANTY.

Devise maintenance

The water heater tank maintenance must be performed according to the plan determined upon delivery. The maintenance book must always be completed after the maintenance man's visit.

Dismantling and Disposal

All the device's materials have to be properly disposed of, according to existing legislation. Uninstalling, transportation and other costs must be paid by the owner.



During of the constant evolution and improvement of the products and services, the manufacturer reserves the right to change or modify the information or of the specifications mentioned herein manual without prior notice or other obligation

BUFFER TANK

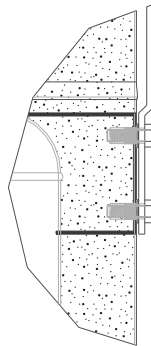
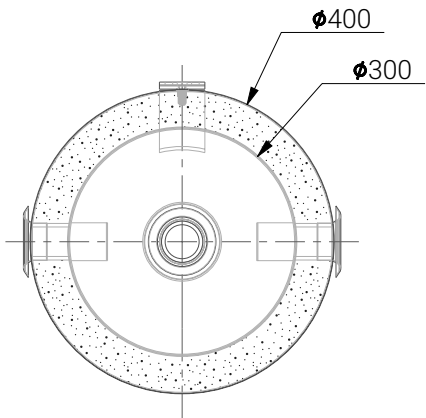
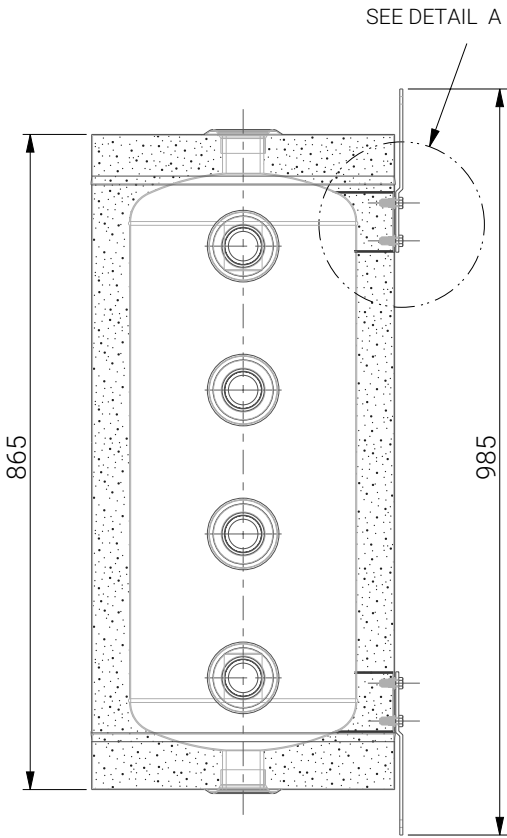
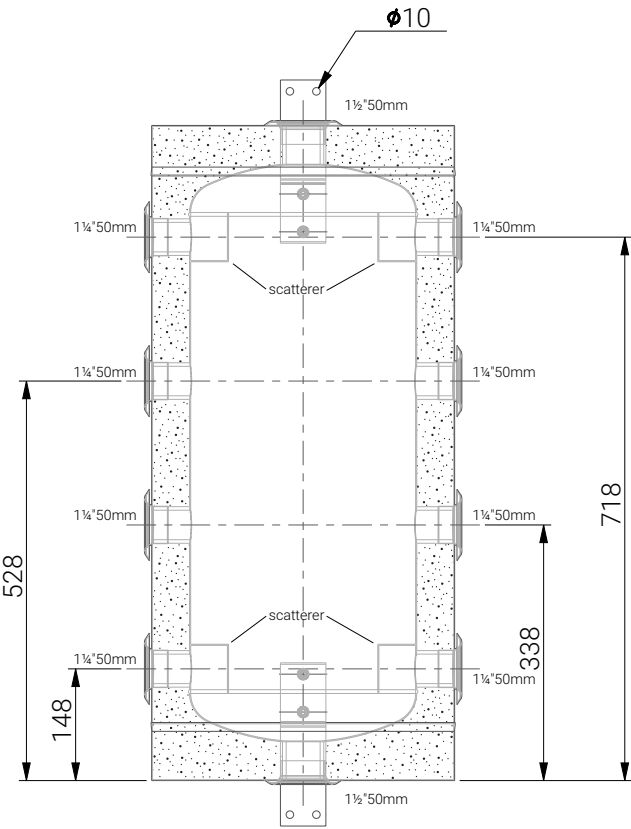

DETAIL A
SCALE 0,300
HANGING SOLUTION A

TRANSFERRING THE BUFFER TANK

The buffer tank should be transferred to the area where it will be placed on its special transfer pallet. Transfer and placement should be carried out by specialised personnel with the appropriate equipment. The area where the tank will be installed should have the required specifications for a boiler room.

USER NOTE



For tank installation and maintenance, the required free space around and above the tank should be ensured during planning, so as to allow carrying out the required procedures.

CAUTION!



RISK OF INJURY by not securing the tank adequately during transport.

- Use only suitable means for transportation.
- Secure the transported load against falling.

CAUTION!



RISK OF INJURY from carrying heavy loads.

- Lifting and transfer should be always carried out by specialised persons.

USER NOTE



Where possible, transport the buffer tank fully packed to the installation room. This ensures protection during transportation.

POSITIONING THE BUFFER TANK

The buffer tank is designed for vertical and can be installed in accordance with its dimensions. The floor has to be level and durable. Please see in the next page the guide for the proper placement of a vertical tank.

CAUTION!



BOILER DAMAGE from frost.

- The installation area must be dry and protected from freezing.

CAUTION!



BOILER DAMAGE from corrosion.

- Use the buffer tank in closed loop systems only.
- Do not use open expansion vessels.

INITIAL START OF BUFFER TANK

Before putting the buffer tank into operation, check its impermeability to avoid leaks during operation.

- Vent the buffer tank by opening the vent/bleed valve or the highest faucet.
- Before heating up, check that the buffer tank and piping are completely filled with water by opening the vent / bleed valve.
- Check all connections, piping and the cleaning port for leaks.

LEAK TEST

USER NOTE



Carry out the buffer tank leak test with potable water only. The maximum test pressure must not exceed 6 bars.

SAFETY RELIEF VALVE

(supplied by the customer)



- Place a sign with the following indication on the safety relief valve: “Don’t close the blow-off line. Water leakage may occur during heating for security reasons.”
- The blow-off line cross-section should be at least equal to the output cross-section of the safety relief valve.
- Check regularly the operational readiness of the safety relief valve with manual test.

OPERATING TIPS

Inform the facility owner that

- the relief valve blow-off line always needs to be kept clear.
- the proper functioning of the relief valve should be checked at regular intervals with manual test.

CAUTION!



BOILER DAMAGE

The buffer tank can be permanently damaged by excessive pressure if the safety relief valve is blocked.

- Always keep the blow-off line of the safety relief valve open.

CAUTION!



BOILER DAMAGE

If the buffer tank ever has to remain empty for several days, signs of corrosion may appear due to residual moisture.

- Thoroughly dry the inside of the tank (e.g. with hot air) and keep the cleaning port cover open.

MAINTENANCE

It is recommended to have the tank checked by a specialized technician after the end of the first operational year. The findings (e.g. high precipitate concentration, security valve losses, anode consumption) shall determine the tank’s maintenance periodicity.

CAUTION!



Under no circumstances should you exercise any welding on the tank’s metal structure. You risk to deteriorate or destroy the tank. If there is such a need it should be effected only by specialized personnel.

CAUTION!



BOILER DAMAGE due to unsatisfactory cleaning and maintenance.

- Carry out cleaning and maintenance of the buffer tank at least every two years.
- Immediately restore all faults to prevent damages!

MAGNESIUM ANODE CHECK

The magnesium anode is a protective anode, which is consumed during the operation of the buffer tank. The magnesium anode should be visually checked at least every year and replaced in case it is necessary. During magnesium anode check the elastic flange shall also be checked for any damages and it shall be replaced if necessary.

- Check the magnesium anode for decay. Replace the magnesium anode if its diameter has been reduced by more than 50%.

USER NOTE



Do not allow the contact of the magnesium anode rod with oil or other lubricants. Make sure that the rod is clean.

MAINTENANCE BOOK

DATE OF PURCHASE: OWNER DATA:

RETAILER:

INSTALLER INFORMATION:

| MAINTENANCE DATE | MAINTAINER INFORMATION | REASON OF VISIT | EXECUTED OPERATIONS | SPARE PARTS USED |
|------------------|------------------------|-----------------|---------------------|------------------|
| | | | | |
| | | | | |
| | | | | |
| | | | | |
| | | | | |
| | | | | |
| | | | | |
| | | | | |
| | | | | |

